



SP X5 3 2

LITHIUM BATTERY POWERED



REMOTE CONTROL



- ✓ Multifunctional
- ✓ Proportional
- ✓ LCD Screen
- ✓ Spare battery
- ✓ Alarm & error diagnostic

HYDRAULIC JIB

- ✓ Hook or winch mode
- ✓ 1 ton MAX capacity
- ✓ 17,3 m MAX height
- ✓ Stored on board & easy to install



SPECIAL FEATURES



- ✓ 400 kg Pick&Carry
- ✓ Virtual Walls
- ✓ Self-diagnostic system
- ✓ All accessories on board
- ✓ Variable displacement pump

WINCH



- ✓ 800 kg single line
- ✓ Up to 125 m rope
- ✓ Single line up to 4 falls
- ✓ Pulley heads and pulley block on board

MAIN BOOM

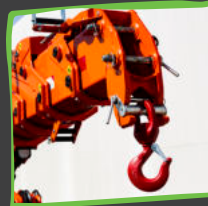

- ✓ 3,2 tons MAX capacity
- ✓ 12 m MAX height
- ✓ 4 hydraulic extension by chain
- ✓ High-resistance steel
- ✓ Hook & winch mode

360° ENDLESS ROTATION

LITHIUM BATTERY POWERED



- ✓ 48 V, 210 Ah
- ✓ Can operate while charging at 220 V
- ✓ Three-phase 7 kW electric motor
- ✓ 400 V external battery charger

OUTRIGGERS

- ✓ 1250 different configurations
- ✓ 4 independent stability areas
- ✓ Self-levelling system

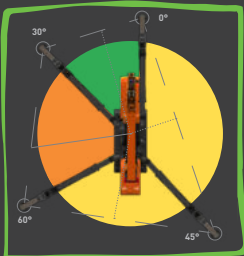

TRACKS

- ✓ White or black tracks
- ✓ 45° hydraulically extendible

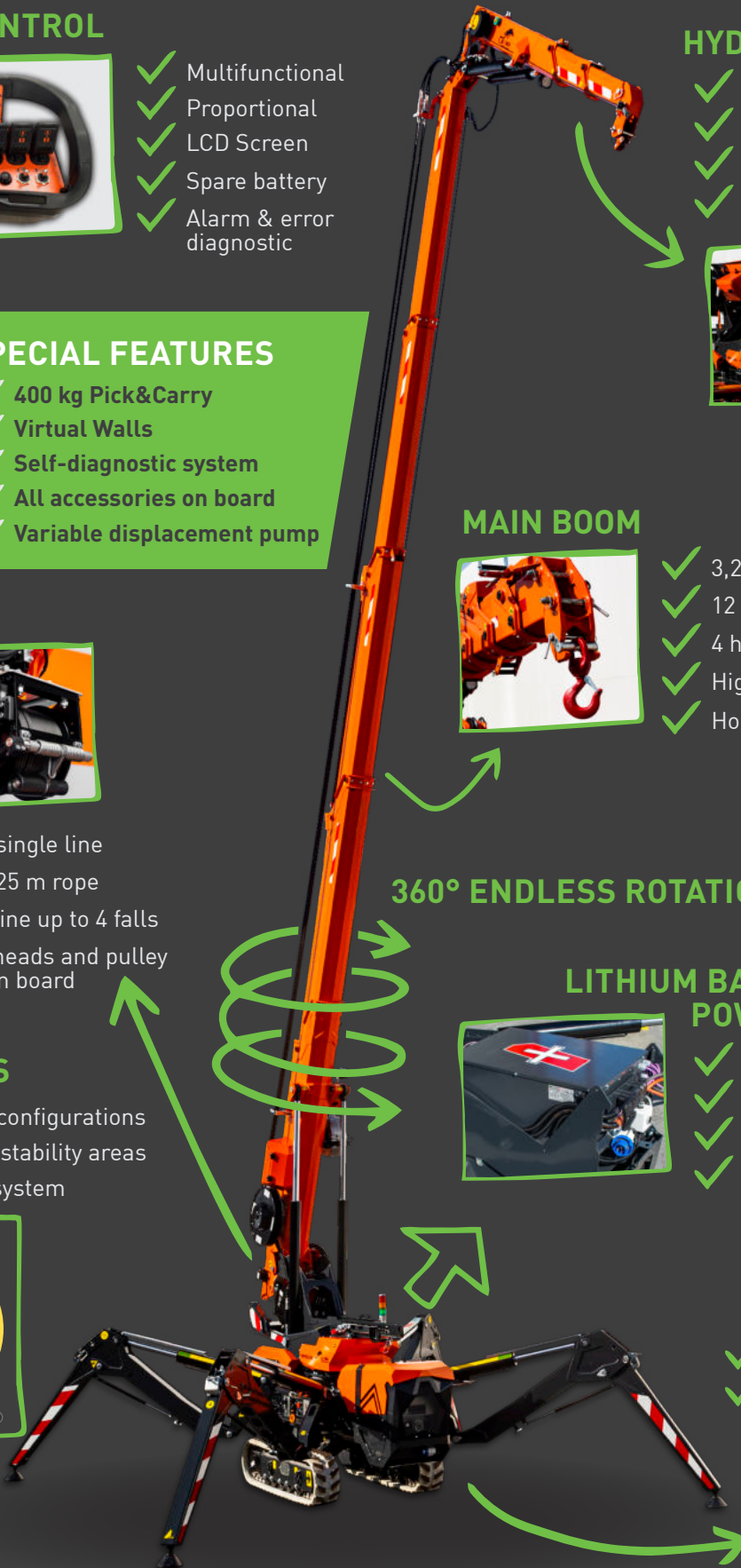
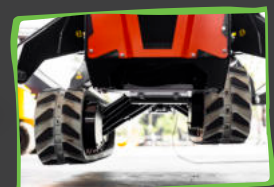



LOAD CHART

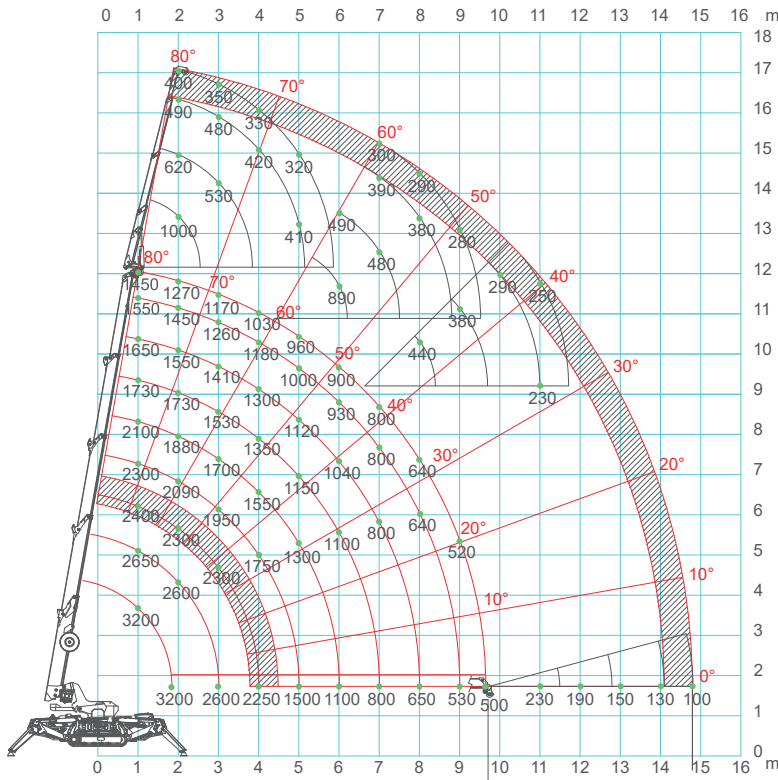

SCAN FOR MORE TECHNICAL DATA



	Kg
SPX532	2520
Hydraulic Jib	210
Winch	52
Electric Power Unit	63



Your Jekko Dealer

Jekko s.r.l. • Via Campardone, 1 - 31014, Colle Umberto (TV) Italy • info@jekko.it • www.jekko-cranes.com
 All specifications and features herein described can be changed without prior advice. All indicated data are indicative only and are not binding as crane performs differently depending on its use.

DIMENSIONS (mm)

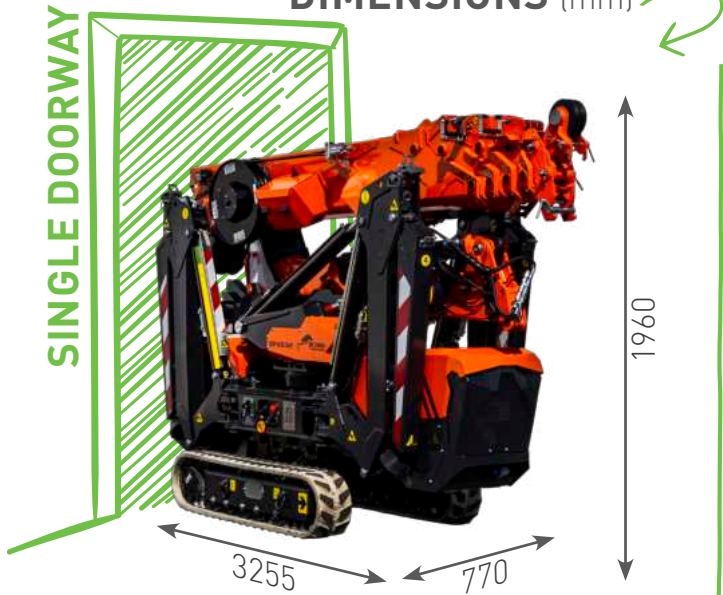

FOOTPRINT

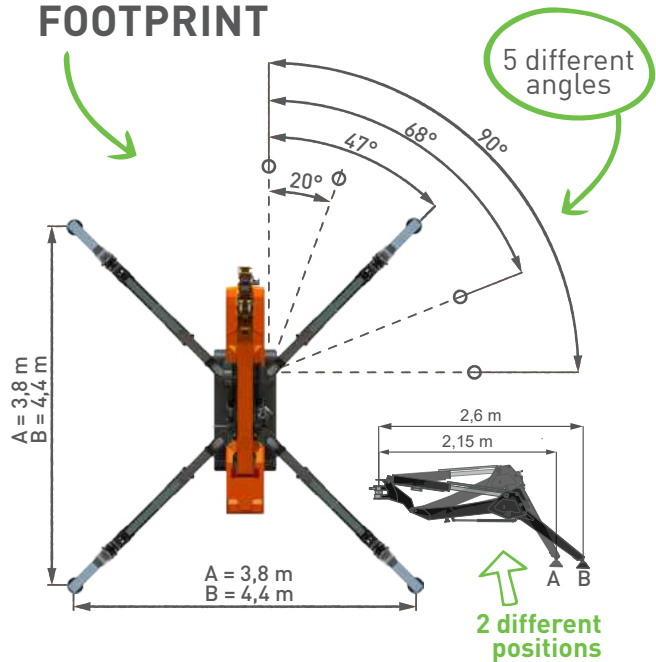

ACCESSORIES

JVM800-R
800 kg glass manipulator



JIB500GR
500 kg steal beam manipulator

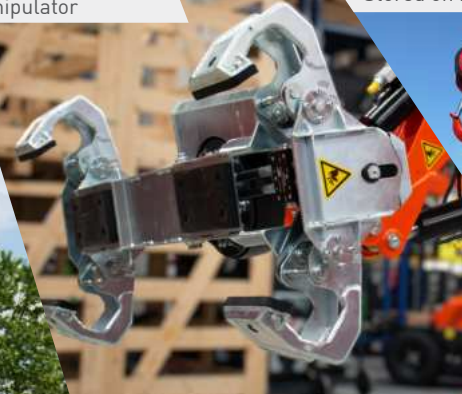

1,2 ton RUNNER JIB
Stored on board



1 ton Hydraulic JIB
Stored on board

